

## M12 Specification

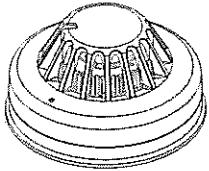

Dimensions	
Height:	56mm
Diameter:	100.5mm
Weight:	78g
Material	PC/ABS

Operating Voltage	10-16V
Current Consumption	0.5mA Normal 14mA Alarm
Alarm Contacts	1A, 30V DC, Normally Closed, Open in Alarm
Visual Indication	Non alarm pulse every 10sec(optional) Alarm -Red Continuous Fault - Yellow Continuous
Reset Time	1 Second Min
Ambient Temp (Max)	Opto mode 60°C Opto-Heat mode 45°C 60°C Rate if Rise mode 45°C 77°C Fixed Temp mode 60°C

## Overview

The M12 is a low current industrial standard sensor which can operate either as an optical, opto/heat combined, rate of rise heat or fixed 77° heat sensor via the selection switches. It is suitable for direct connection to most security alarm control panels or for use with other 12V detection systems.

The detector is equipped with a set of volt free contacts. The detector can be configured to latch or auto-reset from the alarm condition. Also the detector has a dual LED indicator, the red LED is continuous to indicate the alarm condition and can be configured to give a short flash in the normal condition.

The yellow LED will be lit continuously to indicate a smoke sensing chamber fault or that the detector has reached the limit of its contamination compensating ability

## Choosing the right detector

The M12 can be configured using the four position switch located at the back of the detector as;

Optical smoke detector (SW3= Off, SW4 = Off) this detector is suitable for most applications giving the fastest response to slow burning or smouldering fires which give rise to large visible smoke particle.

Opto-heat detector (SW3= On, SW4 = Off) this will respond better to fast clean burning fires yet maintain the advantage of optical detectors when detecting smouldering fires. The thermal enhancement of this detector allows a higher alarm threshold which provides a greater rejection of false alarms. The detector will also give an alarm at temperatures above 60°C.

Rate of Rise heat detector (SW3= Off, SW4 = On) this detector will detector a rapid increase in temperature or temperatures above 60°C and should be used in environments where the ambient conditions might cause false alarms if smoke detection were to be used, for example where there is a high level of dust, fumes, steam or smoke under normal conditions.

Fixed(77°C) heat detector (SW3= On, SW4 = On) this detector will detect temperatures above 77°C and should be used in environments where the ambient conditions might cause false alarms if smoke detection were to be used, for example where there is a high level of dust, fumes, steam or smoke under normal conditions.

In the Optical and Opto-Heat mode the detector automatically compensates for gradual increase in the scatter signal due to contamination e.g. dust build up. If excessive dust occurs, the yellow LED will show continuously. In these circumstances remove the detector head and vacuum around the outside of the mesh. If this fails to solve the problem the detector should be replaced. The yellow LED will be lit continuous if the detector sensor signal begins to reduce below its normal level (chamber monitoring).

**COOPER**



for recycling details see:  
[www.cooper-europe.com](http://www.cooper-europe.com)

Security House,  
Vantage Point Business Village  
Mitcheldean  
Gloucester  
GL17 0SZ  
United Kingdom  
TEL: +44(0)1594 541900  
FAX: +44(0)1594 541910

## Settings

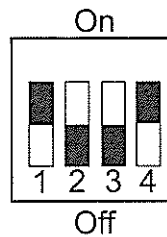
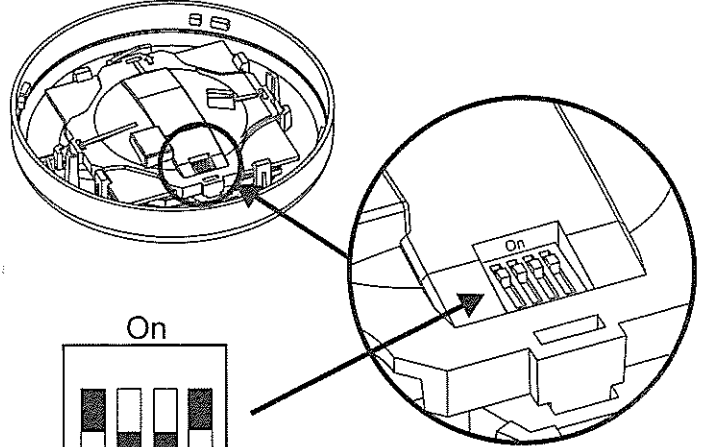

Description	SW1	SW2	SW3	SW4
Detect or Setting				
Opto	N/A	N/A	OFF	OFF
Opto-Heat	N/A	N/A	ON	OFF
Rate of Rise	N/A	N/A	OFF	ON
77°C Fixed	N/A	N/A	ON	ON
LED Off (Normal Mode)	N/A	Off	N/A	N/A
Red LED Pulsing(Normal)	N/A	ON	N/A	N/A
Auto Res et	OFF	N/A	N/A	N/A
Latching Relay	ON	N/A	N/A	N/A

## Utilising Locking Tab

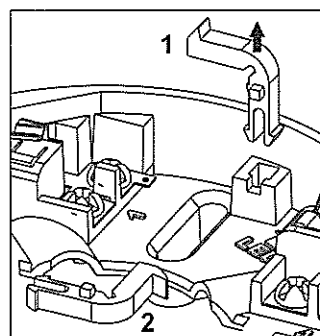

The mounting base includes an optional feature to prevent the removal of the detector without the use of a tool.

1. Remove the standard fit retaining clip.
2. Insert the locking clip which is located at the centre of the base as shown.

Mount the detector onto the base as described in Detector Installation (see over) and rotate fully clockwise until it finally clicks.

The detector is now locked into position. Remove by utilising a suitable tool (eg a thin screwdriver) into the hole in the detector cover. Gently push the tool into the detector and rotate anti-clockwise.

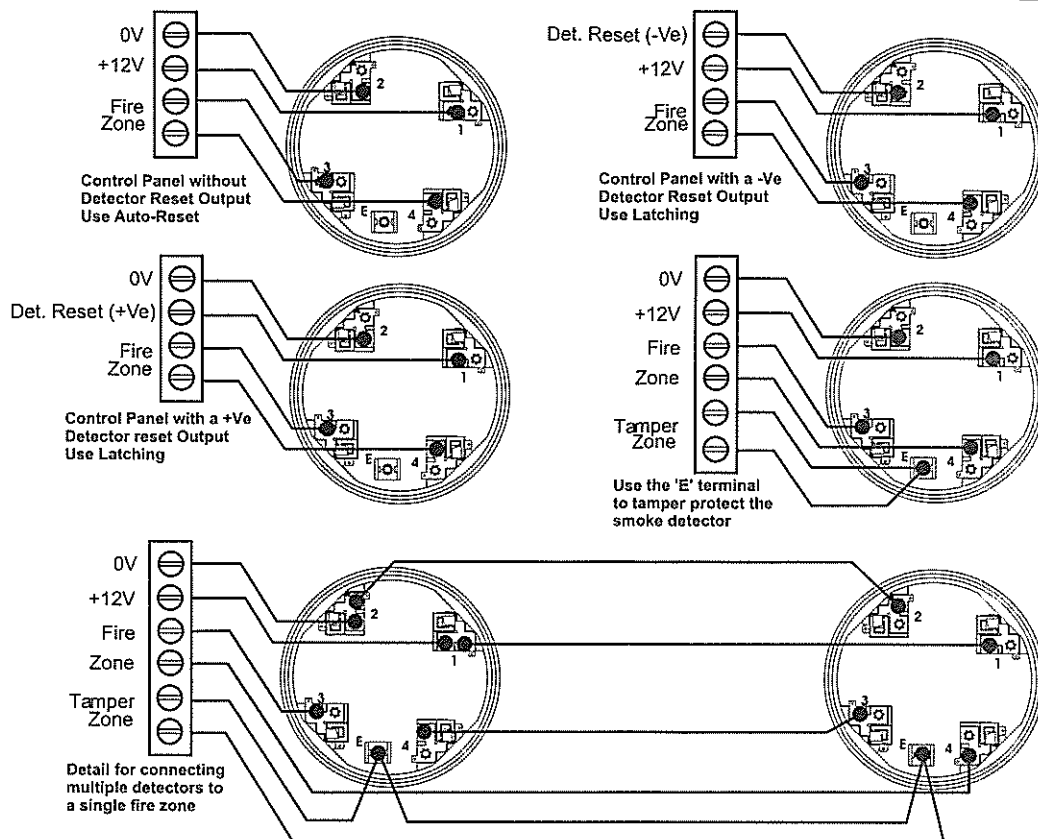

## DETECTOR LOCATION

- Choosing a location: always refer to any local or national guidelines ie. BS5839 pt1; 2002
- In a typical domestic installation at least one detector should be fitted for each level, usually in a central location e.g. hall or landing.
- In commercial installation at least one detector should be install for each area to be protected.
- Always use the most suitable detector for the environment, see choosing the right detector.

## DETECTOR INSTALLATION

- Fit detector to mounting base and rotate clockwise until the detector drops into place.
- Continue to rotate clockwise until the detector clicks and no further rotation is possible.
- If the detectors are required to be locked into position, refer to the mounting base installation instructions (see over leaf).
- Smoke detectors are supplied fitted with dust covers for general protection against airborne contaminants. These must be removed from all detectors before the fire system is commissioned.
- NB. These dust covers do not provide adequate protection against quantities of dust generated by building work, sanding etc. Therefore, detectors should not be installed until this type of work has been completed.

## TESTING

All detectors must be tested following installation or routine service and maintenance. Authorised personnel must be informed that the fire system will be temporarily out of service before commencing testing. When all tests are complete, restore panel to normal operation and notify authorised personnel that the system is operational.

### Smoke Detector Settings:

- Subject the detector to be tested to a controlled amount of an approved synthetic smoke aerosol via a smoke detector test pole. Suitable products are available for example, from No Climb Products Ltd.
- Check that the red LED on the detector lights in alarm within 30 seconds.
- Ensure that the control panel activates into alarm.
- Either reset the detector from the control panel or allow the detector to automatically reset once clear of smoke, if this option has been selected.
- This procedure will test the smoke sensing circuitry of the Opto/Heat Detector.

### Heat Detector Settings:

- Using a heat gun or hair dryer capable of generating temperatures of up to 95°C, direct the heat source towards the heat sensing elements, visible through the side of the outer cover, from a distance of 15 to 30cm. Care should be taken not to allow the plastic surface temperature to exceed 110°C otherwise damage may occur.
- When the temperature reaches the 'Alarm Temperature' (see Specifications above), check that the red LED on the detector lights in alarm.
- Ensure that the control panel activates into alarm.
- Either reset the detector from the control panel or allow the detector to automatically reset once it has cooled down, if this option is selected.
- This procedure will test the heat sensing circuitry of the Opto/Heat Detector.